**Non-active surgical implants —
Mammary implants — Particular
requirements**

*Implants chirurgicaux non actifs — Implants mammaires —
Exigences particulières*





COPYRIGHT PROTECTED DOCUMENT

© ISO 2018

All rights reserved. Unless otherwise specified, or required in the context of its implementation, no part of this publication may be reproduced or utilized otherwise in any form or by any means, electronic or mechanical, including photocopying, or posting on the internet or an intranet, without prior written permission. Permission can be requested from either ISO at the address below or ISO's member body in the country of the requester.

ISO copyright office
CP 401 • Ch. de Blandonnet 8
CH-1214 Vernier, Geneva
Phone: +41 22 749 01 11
Fax: +41 22 749 09 47
Email: copyright@iso.org
Website: www.iso.org

Published in Switzerland

Licensed to Establishment Labs (purchasing@establishmentlabs.com)
ISO Store Order: OP-283853 / Downloaded: 2018-04-19
Single user licence only, copying and networking prohibited

Contents

Page

Foreword	v
Introduction	vi
1 Scope	1
2 Normative references	1
3 Terms and definitions	1
4 Intended performance	3
5 Design attributes	3
6 Materials	3
6.1 General	3
6.2 Cytotoxicity	4
6.3 Residual low molecular weight oligomers	4
6.4 Trace elements	4
6.5 Physico-mechanical properties and characterization	4
6.6 Documentation of materials	4
7 Design evaluation	5
7.1 General	5
7.2 Pre-clinical evaluation	5
7.2.1 General	5
7.2.2 Mechanical tests	5
7.2.3 Physical evaluation	6
7.2.4 Chemical evaluation	7
7.2.5 Biological evaluation	7
7.3 Clinical evaluation	7
7.4 Post-market surveillance	7
8 Manufacturing	7
9 Sterilization	7
10 Packaging	7
11 Information supplied by the manufacturer	8
11.1 General	8
11.2 Product labelling	8
11.3 Information for the user	8
11.3.1 General	8
11.3.2 Resterilization	8
11.3.3 Effects on diagnostic techniques	8
11.4 Marking on implants	8
11.5 Filling materials	8
11.6 Information on expected lifetime	8
11.7 Information for the patient	9
11.7.1 General	9
11.7.2 Patient record label	9
11.7.3 Patient card	9
Annex A (normative) Determination of octamethylcyclotetrasiloxane (D4) and decamethylcyclopentasiloxane (D5) in silicone gels	10
Annex B (normative) Tests for shell integrity	14
Annex C (normative) Mechanical tests on a mammary implant in its implantable state	17
Annex D (normative) Test method for valve competence and injection site competence	23
Annex E (normative) Test for silicone gel cohesion (silicone filling materials only)	25

Annex F (normative) Test for silicone gel penetration (silicone filling materials only)	27
Annex G (informative) Assessment of silicone diffusion from mammary implants using an in vitro method	32
Annex H (informative) Test for surface characteristics	36
Annex I (normative) Information for the user	39
Annex J (normative) Information for the patient	40
Bibliography	41

Foreword

ISO (the International Organization for Standardization) is a worldwide federation of national standards bodies (ISO member bodies). The work of preparing International Standards is normally carried out through ISO technical committees. Each member body interested in a subject for which a technical committee has been established has the right to be represented on that committee. International organizations, governmental and non-governmental, in liaison with ISO, also take part in the work. ISO collaborates closely with the International Electrotechnical Commission (IEC) on all matters of electrotechnical standardization.

The procedures used to develop this document and those intended for its further maintenance are described in the ISO/IEC Directives, Part 1. In particular the different approval criteria needed for the different types of ISO documents should be noted. This document was drafted in accordance with the editorial rules of the ISO/IEC Directives, Part 2 (see www.iso.org/directives).

Attention is drawn to the possibility that some of the elements of this document may be the subject of patent rights. ISO shall not be held responsible for identifying any or all such patent rights. Details of any patent rights identified during the development of the document will be in the Introduction and/or on the ISO list of patent declarations received (see www.iso.org/patents).

Any trade name used in this document is information given for the convenience of users and does not constitute an endorsement.

For an explanation on the voluntary nature of standards, the meaning of ISO specific terms and expressions related to conformity assessment, as well as information about ISO's adherence to the World Trade Organization (WTO) principles in the Technical Barriers to Trade (TBT) see the following URL: www.iso.org/iso/foreword.html.

This document was prepared by Technical Committee ISO/TC 150, *Implants for surgery*,

This third edition cancels and replaces the second edition (ISO 14607:2007), which has been technically revised.

The main changes compared to the previous edition are as follows:

- limit values for trace elements have been added ([6.4](#));
- determination of octamethylcyclotetrasiloxane (D4) and decamethylcyclopentasiloxane (D5) in silicone gels (new [Annex A](#)) has been included;
- mechanical test on a mammary implant in its implantable state (new [Annex C](#), previously [Annex E](#)), specifically the fatigue test ([C.1](#)), has undergone major revision;
- test for silicone gel penetration (silicone filling materials only) (new [Annex F](#)) has been included;
- silicone diffusion assessment from mammary implants by an *in vitro* method (new [Annex G](#), previously [Annex H](#)) has undergone major revision;
- test for surface characteristics (new [Annex H](#), previously [Annex A](#)) has undergone major revision.

Introduction

There are three levels of International Standards dealing with non-active surgical implants. These are as follows (with level 1 being the highest):

- Level 1: General requirements for non-active surgical implants;
- Level 2: Particular requirements for families of non-active surgical implants;
- Level 3: Specific requirements for types of non-active surgical implants.

This document is a level 2 standard and contains particular requirements for a family of mammary implants.

The level 1 standard, ISO 14630, contains requirements that apply to all non-active surgical implants. It also indicates that there are additional requirements in the level 2 and level 3 standards.

To address all requirements, the lowest available level is the level to start with.

Non-active surgical implants — Mammary implants — Particular requirements

1 Scope

This document specifies particular requirements for mammary implants.

With regard to safety, this document specifies requirements for intended performance, design attributes, materials, design evaluation, manufacturing, packaging, sterilization, and information supplied by the manufacturer.

2 Normative references

The following documents are referred to in the text in such a way that some or all of their content constitutes requirements of this document. For dated references, only the edition cited applies. For undated references, the latest edition of the referenced document (including any amendments) applies.

ISO 34-1:2015, *Rubber, vulcanized or thermoplastic — Determination of tear strength — Part 1: Trouser, angle and crescent test pieces*

ISO 37:2017, *Rubber, vulcanized or thermoplastic — Determination of tensile stress-strain properties*

ISO 4287, *Geometrical Product Specifications (GPS) — Surface texture: Profile method — Terms, definitions and surface texture parameters*

ISO 7619-1, *Rubber, vulcanized or thermoplastic — Determination of indentation hardness — Part 1: Durometer method (Shore hardness)*

ISO 10993-1, *Biological evaluation of medical devices — Part 1: Evaluation and testing within a risk management process*

ISO 10993-5, *Biological evaluation of medical devices — Part 5: Tests for in vitro cytotoxicity*

ISO 10993-18, *Biological evaluation of medical devices — Part 18: Chemical characterization of materials*

ISO 11607-1, *Packaging for terminally sterilized medical devices — Part 1: Requirements for materials, sterile barrier systems and packaging systems*

ISO 14155, *Clinical investigation of medical devices for human subjects — Good clinical practice*

ISO 14630:2012, *Non-active surgical implants — General requirements*

ASTM D412–16, *Standard Test Methods for Vulcanized Rubber and Thermoplastic Elastomers — Tension*

ASTM D624–00 (2012), *Standard guide for evaluation of thermoplastic polyurethane solids and solutions for biomedical applications*

ASTM D792–13, *Standard Test Methods for Density and Specific Gravity (Relative Density) of Plastics by Displacement*

ASTM D2240–15, *Standard Test Method for Rubber Property — Durometer Hardness*

3 Terms and definitions

For the purposes of this document, the terms and definitions given in ISO 10993-1, ISO 14155 and ISO 14630 and the following apply.

ISO 14607:2018(E)

ISO and IEC maintain terminological databases for use in standardization at the following addresses:

- IEC Electropedia: available at <http://www.electropedia.org/>
- ISO Online browsing platform: available at <https://www.iso.org/obp>

3.1 anterior projection

maximum height of the implant when placed with its base on a flat horizontal surface

Note 1 to entry: For inflatable and adjustable implants, this applies to the implant's nominal volume.

3.2 base dimension

length of the major axis and the length of the minor axis when the implant is placed with its base on a flat horizontal surface

Note 1 to entry: For inflatable and adjustable implants, this applies to the implant's nominal volume.

3.3 cure

process of transforming uncured polymer into an elastic material through a covalent crosslinking reaction

3.4 diffusion

movement of material in and/or out of an implant through an intact shell

3.5 filling volume

volume of the material contained within the shell or volume of the solution necessary to fill an inflatable or adjustable mammary implant

3.6 implant volume

volume of the shell and filler material together

3.7 injection site

component designed to be penetrated by a needle to alter the volume of the implant

3.8 mammary implant

implant with a shell which has been filled by the *manufacturer* (3.9) or is designed to be filled by the surgeon, and is intended to add or replace volume of the breast

3.9 manufacturer

natural or legal person with responsibility for the design, manufacture, packaging and labelling of a device before it is placed on the market under his own name, regardless of whether these operations are carried out by that person himself or on his behalf by a third party

[SOURCE: ISO 10993-18:2005, 3.2]

3.10 orientation means

mark in or on the implant to assist the surgeon in positioning the implant

3.11**shell**

envelope of the *mammary implant* (3.8)

3.12**seam**

seal junction of implant materials fused or adhered together

3.13**silicone elastomer**

synthetic rubber obtained by the crosslinking of silica reinforced silicone polymer chains essentially made of repeat diorganosiloxane units

3.14**silicone gel**

partially crosslinked silicone polymer, featuring a semisolid material consisting of crosslinked silicone polymer and liquid silicone polymer [silicone oil or polydimethylsiloxane (PDMS)]

3.15**silicone polymer**

polymer chains essentially made of repeat diorganosiloxane units

3.16**supplier**

company who manufactures and/or supplies the raw materials and components used for the production of mammary implants

3.17**tensile set**

tensile elongation remaining after a specimen has been stretched and allowed to relax in a controlled manner

3.18**valve**

shell component allowing inflation of mammary implant with variable volumes of liquids when needed and providing a tight closure the rest of the time

4 Intended performance

The requirements of ISO 14630:2012, Clause 4, shall apply.

5 Design attributes

The requirements of ISO 14630:2012, Clause 5, shall apply.

6 Materials**6.1 General**

The requirements of ISO 14630:2012, Clause 6, shall apply.

Materials shall be manufactured and tested under a quality management system.

The information stated within [Clause 6](#) shall be available from the manufacturer.

NOTE This information can typically be obtained from the raw material supplier.

When other materials than silicone are used, the manufacturer shall establish suitable test methods and acceptance criteria to demonstrate the appropriate performance and safety of the implant.

6.2 Cytotoxicity

The components of each production raw material lot shall be cured and tested for cytotoxicity in accordance with ISO 10993-5. No cytotoxic effects, as defined in ISO 10993-5, shall be induced by the material tested, or throughout the culture.

6.3 Residual low molecular weight oligomers

The combined residual oligomers, cyclotetrasiloxane (D4) and cyclopentasiloxane (D5), in uncured or cured gel shall be tested in accordance with [Annex A](#).

6.4 Trace elements

The components of each production raw material lot shall be in accordance with the [Table 1](#) specifications on metal impurities.

Table 1 — Metals impurities limit content

Element	Content limit per element (mg/kg)
As, Pb, Cd, Hg, V, Mo, Se, Co, Sb, Ba, Cr, Cu, Sn, Ni	≤10

If one of these metals comprises part of the formulation component (for example BaSO₄), it is not considered an impurity, and shall be considered for the biological evaluation of the implant.

6.5 Physico-mechanical properties and characterization

The following mechanical characteristics of silicone elastomers, after cure, shall be available for every raw material lot:

- elongation at break (%), according to ISO 37:2017 or ASTM D412-16
- tensile strength at break (MPa) according to ISO 37:2017 or ASTM D412-16
- modulus at 100 % elongation (MPa), according to ISO 37; 2017 or ASTM D412-16
- hardness (IRHD), according to ASTM D2240-15 or ISO 7619-1
- relative density, or specific gravity, according to ASTM D792-13
- tear strength (kN/m), according to ISO 34-1:2015, Method C, or ASTM D624-00 (2012), Die B.

The penetration or bulk gel hardness of silicone gel, after cure, shall be available for every raw material lot.

6.6 Documentation of materials

The manufacturer shall require from the supplier for each type of material, a certificate of analysis including at least the following information:

- a) supplier's name, address and telephone number;
- b) material reference;
- c) for silicone material the range of properties (as defined in [6.5](#)), with defined specification limits and test methods, including cure conditions. For other materials, same type of information shall be required, if applicable.

7 Design evaluation

7.1 General

The requirements of ISO 14630:2012, 7.1, shall apply.

The design of mammary implants shall be based on a risk assessment taking into account the fact that their benefit is deemed to be primarily aesthetic and psychological in nature, whether the application is for reconstructive and/or cosmetic purposes.

7.2 Pre-clinical evaluation

7.2.1 General

The pre-clinical evaluation of mammary implants shall conform to ISO 14630:2012, 7.2, and fulfil the requirements of ISO 10993-1.

The texture of the breast implant shell is to be taken into account when demonstrating biocompatibility.

Extrapolation of biocompatibility data for smooth breast implants is not sufficient for demonstrating the biocompatibility of textured breast implants.

Where no test is described in this document, or when the test described is not applicable, description for the alternative validated test method, test specimen preparation used and test results shall be documented by the manufacturer. The adequacy of the pass/fail criteria adopted for the evaluation shall be verified prior to testing.

All testing samples shall be representative of finished sterilized devices.

A worst-case assumption shall be considered.

The sample size selected shall be based on a statistical rationale, which shall be justified and documented. Where appropriate, for materials other than silicone, the manufacturer shall consider and develop tests as indicated in [7.2.2](#) to [7.2.5](#).

7.2.2 Mechanical tests

7.2.2.1 Shell integrity

7.2.2.1.1 General

The integrity of the shell shall be evaluated.

The following properties of the silicone elastomer shell shall be tested in accordance with [Annex B](#).

7.2.2.1.2 Elongation

The elongation of the silicone elastomer shell shall be tested in accordance with [B.1.2](#).

7.2.2.1.3 Tensile set

The tensile set of the silicone elastomer shell shall be tested in accordance with [B.1.3](#).

7.2.2.1.4 Strength of joints, seams or seals

The resistance to failure of joints, seams and seals shall be tested in accordance with [B.2](#).

7.2.2.2 Implant resistance

7.2.2.2.1 Fatigue resistance test

The fatigue resistance test shall be conducted in accordance with [C.1](#).

7.2.2.2.2 Impact resistance test

The impact resistance test shall be conducted in accordance with [C.2](#).

7.2.3 Physical evaluation

7.2.3.1 Design of shell

Surfaces both inside and outside of the shell shall be suitable to minimize frictional abrasion both between shell-to-shell surface and between shell surface and the implantation site. If such frictional abrasion is likely to be a significant problem, the manufacturer shall indicate any relevant tests carried out to ensure the suitability of the shell when implanted.

7.2.3.2 Valve or injection site competence

The competence of the valve or injection site shall be tested in accordance with [Annex D](#).

7.2.3.3 Filling material

7.2.3.3.1 General

The physical compatibility between the filling material and the shell shall be demonstrated by providing long-term data on shell performance and integrity.

7.2.3.3.2 Silicone gel cohesion

If silicone gel is used as filling material, cohesivity testing shall be performed in accordance with [Annex E](#).

7.2.3.3.3 Silicone gel penetration

Penetration of silicone gel shall be evaluated. Testing to verify if specifications are met shall be performed in accordance with [Annex F](#).

NOTE It is not possible to perform this test on a finished device. Therefore, it is usually performed as a process control (see [E.1](#)).

7.2.3.4 Diffusion test

Diffusion from the whole implant shall be evaluated.

NOTE There are currently two test methods described in [Annex G](#) and ASTM F703-18 that might provide some valuable information concerning the diffusion. These two methods are given as examples but are not mandatory.

7.2.3.5 Volume

The volume of the implants filled by the manufacturer shall be within $\pm 2,5$ % of the implant volume stated on the labelling.

7.2.3.6 Dimensions

The actual device base dimensions and anterior projection shall be measured and recorded.

7.2.3.7 Surface

If the surface is specially treated or processed in order to form a specific texture, the surface characteristics shall be assessed and the test results shall be recorded.

[Annex H](#) can be used as a guide.

7.2.3.8 Surface contamination

The manufacturer shall conduct a risk assessment to define appropriate limits for particulate contamination of the surface of the finished mammary implant.

7.2.4 Chemical evaluation

Each shell, filler material and, if applicable, coating material shall be chemically evaluated in accordance with ISO 10993-18.

7.2.5 Biological evaluation

The implant shall be evaluated in accordance with the requirements of ISO 10993-1, within a risk management process.

7.3 Clinical evaluation

The requirements of ISO 14630:2012, 7.3, shall apply.

The purpose of the clinical evaluation is to estimate the frequency and rate at which complications occur, e.g. capsular contracture and ruptures/deflation of implants, after implantation of a mammary implant.

7.4 Post-market surveillance

The requirements of ISO 14630:2012, 7.4, shall apply.

8 Manufacturing

The requirements of ISO 14630:2012, Clause 8, shall apply.

9 Sterilization

The requirements of ISO 14630:2012, 9.1, 9.2 and 9.4, shall apply.

Implants shall be supplied sterile.

10 Packaging

The requirements of ISO 14630:2012, Clause 10, apply.

Packaging design shall be validated according to ISO 11607-1.

11 Information supplied by the manufacturer

11.1 General

The requirements of ISO 14630:2012, 11.1, shall apply.

The information shall be supplied by the manufacturer on the label, package insert or any other media (e.g. user manual, patient information).

NOTE Information supplied by the manufacturer can be subject to national or regional regulations.

11.2 Product labelling

The requirements of ISO 14630:2012, 11.2, shall apply.

Additionally, the labelling shall include the following details necessary for identification of the implant:

- a) implant dimensions (base dimensions, anterior projection and implant volume), and
- b) filling volume, for inflatable or adjustable mammary implant.

11.3 Information for the user

11.3.1 General

The requirements of ISO 14630:2012, 11.3, shall apply.

The manufacturer shall provide the user with the information, as specified in [Annex I](#).

11.3.2 Resterilization

The requirements of ISO 14630:2012, 9.3.2, shall apply.

11.3.3 Effects on diagnostic techniques

The effect of the implant on diagnostic techniques, such as mammography or magnetic resonance imaging (MRI), shall be provided to the user.

11.4 Marking on implants

In addition to the requirements of ISO 14630:2012, 11.5, the implant volume shall be indicated on the implant.

11.5 Filling materials

For inflatable and adjustable implants, the manufacturer shall indicate the filling materials and filling instructions.

11.6 Information on expected lifetime

The manufacturer shall provide information on the expected duration of performance of the device as intended, preferably expressed as percentage implant durability at 10 years (or earlier if 10-year information is not yet available), in accordance with the Kaplan Meier method or an alternative

statistical method. Such relevant information includes the indication of factors that could have a significant influence on the actual lifetime of an individual implant.

NOTE In practice, it is not possible to predict accurately the actual lifetime of an individual implant. It is well understood that several factors are beyond the control of the manufacturer. These factors might have a significant effect on the lifetime of an individual device. The factors include the actual implantation procedure, the anatomy and state of health of the patient, the behaviour and activities (e.g. sporting activities), as well as predictable and unpredictable external mechanical influences.

Examples of possible methods include:

- a) indicating a probability of lifetime reaching an expected value;
- b) indicating a range of anticipated lifetime;
- c) indicating statistical information derived from data obtained by means of similar devices already implanted.

11.7 Information for the patient

11.7.1 General

The manufacturer shall provide the user with the information destined for the patient, as specified in [Annex J](#).

NOTE The manufacturer is not responsible for the transfer of information from the user to the patient, nor for having the patient sign the consent form.

11.7.2 Patient record label

The package shall include label(s) for use on the patient record and patient card, including at least the following information:

- a) the manufacturer identification;
- b) the manufacturer's serial number or lot code;
- c) the commercial reference of the implant;
- d) the implant volume;

11.7.3 Patient card

The package shall include a patient card for the physician to complete and give to the patient.

NOTE The manufacturer is not responsible for handing over the patient card to the patient.

Annex A (normative)

Determination of octamethylcyclotetrasiloxane (D4) and decamethylcyclopentasiloxane (D5) in silicone gels

A.1 Objective

This annex describes a quantitative technique for the determination of octamethylcyclotetrasiloxane (D4) and decamethylcyclopentasiloxane (D5) in cured or uncured silicone gels.

A.2 Principle

The quantitative analysis of D4 and D5 in a cured or uncured silicone gel is carried out using a gas chromatograph (GC) equipped with a flame ionizing detector (FID) and a capillary column or using a gas chromatograph with a mass spectrometer (GC-MS). When using a gas chromatograph without a mass spectrometer, the identification of D4 and D5 in the silicone gel is determined by comparing the retention times of the eluted molecules found in the silicone gel to the known retention times of D4 and D5 as determined through the analysis of D4 and D5 calibration standards. When using a gas chromatograph with a mass spectrometer, the identification of D4 and D5 in the silicone gel is determined by comparing the mass spectra of the test specimen to a mass spectra reference library. The concentration of D4 and D5 in the silicone gel is determined using calibration curves developed through the analysis of D4 and D5 calibration standards at known concentrations. Calibrations may be performed using either an internal or an external calibration standard. Results shall be reported to the nearest part per million (ppm) or milligram per kilogram (mg/kg) on a weight per weight (w/w) basis.

A.3 Test specimen preparation

The silicone gel can be analysed in its cured or uncured state. The silicone gel shall be mixed per the material manufacturer's recommended mixing procedure. If the silicone gel is analysed in its cured state, the silicone gel shall be cured per the material manufacturer's recommended cure schedule. The silicone gel can be analysed neat or diluted using a volatile organic solvent. The test specimen preparation method shall be calibrated at time of use.

A.4 Reagents

A.4.1 Volatile organic solvent (GC grade), as required.

A.4.2 D4 and D5 Calibration standards (≥99 % purity).

A.4.3 Internal/External standard (≥99 % purity).

A.5 Apparatus

A.5.1 Gas chromatograph (GC) with flame ionizing detector (FID) or gas chromatograph with mass spectrometer (GC-MS).

A.5.2 Analytical balance.

A.5.3 Gas chromatograph syringe.**A.5.4 Transfer pipettes.****A.5.5 Glass vials.****A.5.6 Volumetric flasks.****A.6 Experimental precautions**

The usual safety recommendations apply and the following precautions shall be taken:

- a) the same gas chromatography parameters shall be used for the analysis of the silicone gel as were used for the analysis of the calibration standards;
- b) results shall not be extrapolated beyond the established calibration range;
- c) rinse glassware and flush gas chromatograph syringe with the same volatile organic solvent as used for the test specimen analysis;
- d) prior to the test specimen analysis, verify that the calibration is valid for the range used for measurement;
- e) the volatile organic solvent shall be chemically non-reactive with the internal/external standard, the calibration standards and the test specimen;
- f) the internal standard, the calibration standards and the test specimen shall be soluble in the volatile organic solvent;
- g) the solvent peak(s), when analysed via gas chromatography, shall not interfere with the internal standard peak or the calibration standards peaks.

A.7 Procedure**A.7.1 Number of experiments**

The experiment shall be carried out on one test specimen; i.e. one test specimen shall be prepared and analysed via gas chromatography.

A.7.2 Preparation of calibration standards and construction of calibration curves

Prepare a series of D4 and D5 calibration standards at various concentrations such that the calibration range will bracket the expected D4 and D5 concentration of the silicone gel. The calibration range will need to be adjusted if the D4 or D5 concentration measured in the silicone gel exceeds the established calibration range.

Turn on the gas chromatograph per the material manufacturer's recommended procedure. Verify that the gas chromatograph is functioning properly and is capable of performing the analysis.

Analyse the calibration standards using the same gas chromatography parameters as will be used for the analysis of the silicone gel. Construct a calibration curve (response factor vs. known analytic concentration) for D4 and D5 and verify the calibration by determining the linearity of the calibration curves via linear regression (see [A.10](#)).

A.7.3 Test specimen analysis

Prepare the test specimen for analysis using a validated test specimen preparation method.

Turn on the gas chromatograph per the material manufacturer's recommended procedure. Verify that the gas chromatograph is functioning properly and is capable of performing the analysis. The gas chromatography method shall be validated by determining the selectivity, accuracy, range, robustness; precision and limit of quantitation of the gas chromatography method (see [A.10](#)). A calibration verification and a method blank shall be performed prior to the test specimen analysis.

Analyse the silicone gel using a validated gas chromatography method. The same gas chromatography parameters shall be used for the test specimen analysis as were used for the calibration standards analysis. Determine the concentration of D4 and D5 in the silicone gel and verify that the concentrations of D4 and D5 fall within the established calibration range. Results are not valid if the results exceed the established calibration range.

A.8 Calculation

Calculate the concentrations of D4 and D5 for the analysis on a weight per weight (w/w) basis to the nearest milligram per kilogram (mg/kg) or part per million (ppm).

Record the:

- a) results from the analysis;
- b) limit of quantitation (LOQ).

A.9 Specification

The average concentration of D4 and D5 combined in the silicone gel, expressed on a weight per weight (w/w) basis, shall be less than or equal to 50 mg/kg or 50 ppm.

NOTE While the material level of 50 mg/kg has been shown to be suitable historically, the safety of absolute levels in the implant will have to be shown by the implant manufacturer (see [7.2.1](#)).

A.10 Analytical validation

Selectivity shall be established by verifying that an adequate separation factor exists for the analytes of interest (D4 and D5) in the test specimen matrix.

Linearity shall be established across the range of use utilizing a minimum of five calibrations standards.

The correlation coefficient for each calibration curve shall be a minimum of 0,995.

The percent recovery shall be 80 % to 120 %.

Robustness shall be determined by examining the reliability of the analysis with respect to deliberate variations in method parameters (e.g. different gas chromatograph columns, carrier gas flow rates, etc.).

The limit of quantitation (LOQ) shall be determined by using acceptable analytical technique such as measuring the signal-to noise ratio or determining the standard deviation of the response and the slope and shall be verified.

A.11 Test report

At least, the following information shall be recorded:

- a) description of implant specimen, including manufacturer name, serial number or lot code testing date;
- b) testing date;
- c) identity of the responsible tester;

d) test results.

Annex B (normative)

Tests for shell integrity

B.1 Shell material

B.1.1 Test specimen preparation

Unless otherwise indicated below, all test specimens shall be prepared using die Type 2, as detailed in ISO 37:2017. Where the implant is prefilled, the silicone gel or other material shall be removed. The tests shall include mandrel marks or orientation means if these are present on the shell. If required, propan-2-ol is recommended to aid test specimen cleaning.

The tests are most conveniently carried out using a commercially available tensile testing frame. In all cases, the test specimen shall be securely clamped at either end and then extended at a constant rate of (500 ± 10) mm/min.

B.1.2 Elongation

Elongation shall be determined in accordance with the requirements of ISO 37:2017.

Elongation shall be a minimum of 450 %.

B.1.3 Tensile set

The test shall be carried out in accordance with the requirements of ISO 37:2017.

The test specimen shall be elongated to (300 ± 15) %, maintained at this elongation for $(3,0 \pm 0,3)$ min, and then relaxed to the starting position. After this, within 1 min, the tensile set shall be a maximum of 10 %.

B.2 Strength of seams

B.2.1 General

Test specimen shall be prepared as outlined in [B.1.1](#).

The test specimen shall be taken such that the seam region is within the reference portion of the test specimen.

Testing configuration shall be as illustrated in [Figure B.1](#).

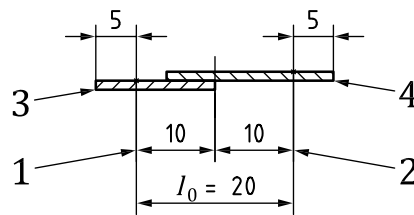
**Key**

- 1, 2 reference marks — extensometer
3, 4 point of fixation of the test specimen

Figure B.1 — Specimen loading configuration

Due to the wide range of the bonded area it might not be possible that l_0 be equal to 20 mm. In this case a value of l_0 greater than the width of the bonded area shall be determined by the manufacturer. The bonded area shall be placed in the middle of the l_0 distance and the tensile area.

B.2.2 Critical seams

The test specimen shall be taken as indicated in [Figure B.2](#).

The area of the shell adjacent to the bonded area, designated l_0 in [Figure B.1](#) and [Figure B.2](#), shall not fail when elongated to $(300 \pm 15) \%$ and held at this value for a period of (10 ± 1) s.

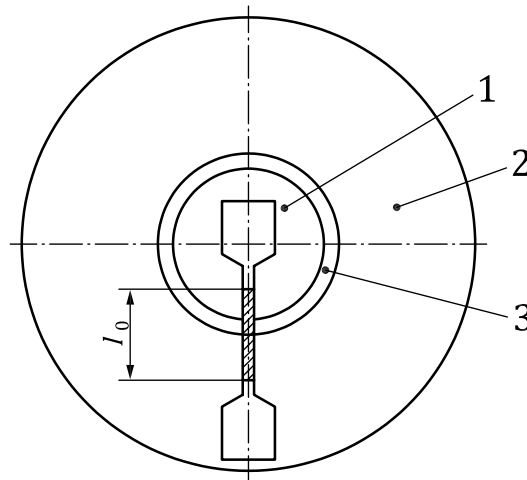
**Key**

- 1 patch
2 shell
3 junction

Figure B.2 — Test specimen**B.2.3 Non-critical seams**

The area of the shell adjacent to the bonded area shall not fail when elongated to $(100 \pm 5) \%$ and held at this value for a period of (10 ± 1) s.

NOTE Non-critical seams to shell integrity include fixations, suture tabs, orientation marks and valve covers.

B.3 Test report

At a minimum, the following information shall be registered for each shell integrity test:

- a) description of implant specimen, including manufacturer name, serial number or lot code;
- b) testing date;
- c) identity of the responsible tester;
- d) test results, according [B.1.2](#), [B.1.3](#) and [B.2.2](#) and, if applicable, [B.2.3](#).

Annex C (normative)

Mechanical tests on a mammary implant in its implantable state

C.1 Fatigue test

C.1.1 Principle

This test method determines the resistance of the implant to fatigue.

C.1.2 Materials

Mammary implant.

C.1.3 Apparatus

The apparatus is shown schematically in [Figure C.1](#). It consists of a fixed plate and a mobile plate, the latter being attached to a motor via a connecting arm, which generates alternating motion in the mobile plate. The mobile plate also includes an adjustment mechanism such that its distance from the fixed plate can be varied. Thus, the implant can be compressed as required.

The total length of travel of the mobile plate shall be (40 ± 4) mm, corresponding to (20 ± 2) mm travel in each direction from the central starting position. The motor shall be geared so as to produce (200 ± 5) cycles per minute, which corresponds to a frequency of $(3,3 \pm 0,1)$ Hz.

C.1.4 Procedure

The implant shall be held by compression force between two opposing horizontally positioned support plates.

NOTE Deformations are introduced into the implant by the alternating movement of one of the plates. The compression force ensures the prosthesis remains in position between the plates, thus allowing the implant to be subjected to shear forces.

Inflatable implants shall be filled according to the manufacturer's instructions prior to the test.

The test shall be performed at a temperature of (23 ± 2) °C, as follows:

- a) Place the implant between the two plates and adjust the compression force to 50 N.
- b) The test shall proceed for $6,5 \times 10^6$ cycles.
- c) Inspect the implant in accordance with [C.1.5](#).

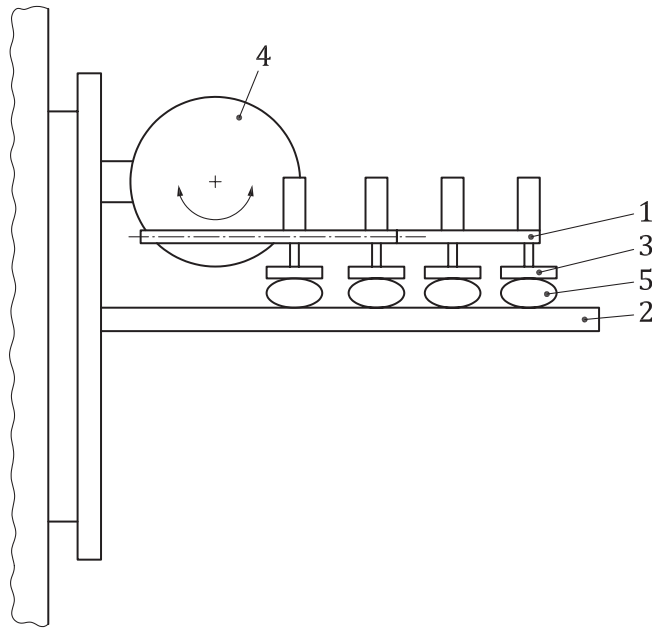

a) Apparatus lateral view

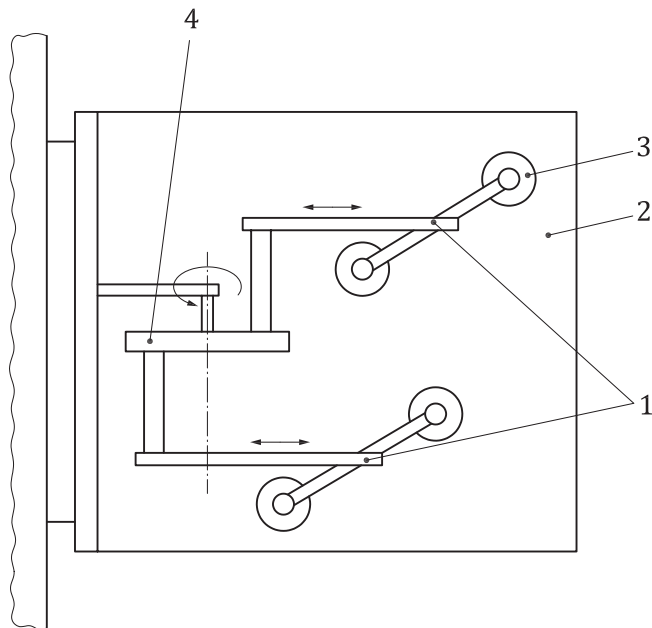

b) Apparatus superior view

Key

- | | | | |
|---|----------------|---|----------|
| 1 | connecting arm | 4 | motor |
| 2 | fixed plate | 5 | specimen |
| 3 | mobile plate | | |

Figure C.1 — Fatigue horizontally test apparatus

C.1.5 Requirements

Following this test, no rupture of the implant shell shall be present on the mammary implant when observed visually at a ×10 magnification.

Marks from the testing friction of the support plates shall not be considered as implant failures.

C.1.6 Test report

Report testing shall include, at least the following:

- a) description of specimen, including manufacturer name, model, serial number or lot code and the prostheses projection;
- b) description of the test equipment used;
- c) test results; in case of failure, a description of failures visually observed and the number of cycles reached;
- d) testing date;
- e) identity of the responsible tester.

C.2 Impact resistance test

C.2.1 Principle

This test method determines the impact resistance of mammary implants. The test is based on the vertical drop of a specified mass on the implant. The implant is subjected to an impact force proportional to the mass of the implant. The implant force is varied by adjusting the vertical distance from which the mass of $(4,4 \pm 0,1)$ kg is allowed to fall.

The drop height is given by the following Formula:

$$H = 0,95m + 144$$

where

H is the drop height, in mm;

m is the implant mass, in g.

C.2.2 Apparatus

The apparatus is shown schematically in [Figure C.2](#). It consists of a frame equipped with a mobile gantry to which a total mass of $(4,4 \pm 0,1)$ kg is attached. When disconnected from the gantry, the mass runs freely on two guide runners, which ensures a regular and reproducible drop to the base of the frame. A metal plate of (250 ± 5) mm diameter comes into contact with the implant.

The gantry contains a fixing mechanism such that it can be positioned on the frame at a variable height from the base. The frame may include a height gauge and manual winch for positioning, and the gantry may include an electronically controlled release mechanism for the mass.

When the mass holding mechanism is released, the mass falls on the implant. The force generated is proportional to the starting height.

C.2.3 Procedure

Inflatable implants shall be filled according to the manufacturer's instructions prior to the test.

The test shall be performed as follows.

- a) Weigh the implant.
- b) Calculate the drop height (in millimetres) according to the implant mass and the Formula given in [C.2.1](#).

ISO 14607:2018(E)

- c) Note the implant projection and position the gantry, such that the total distance between the impact weight and the frame base consists of the calculated drop height and implant projection.
- d) Position the implant on the frame base, centred directly beneath the impact plate.
- e) Release the mass retaining mechanism.
- f) Inspect the implant.

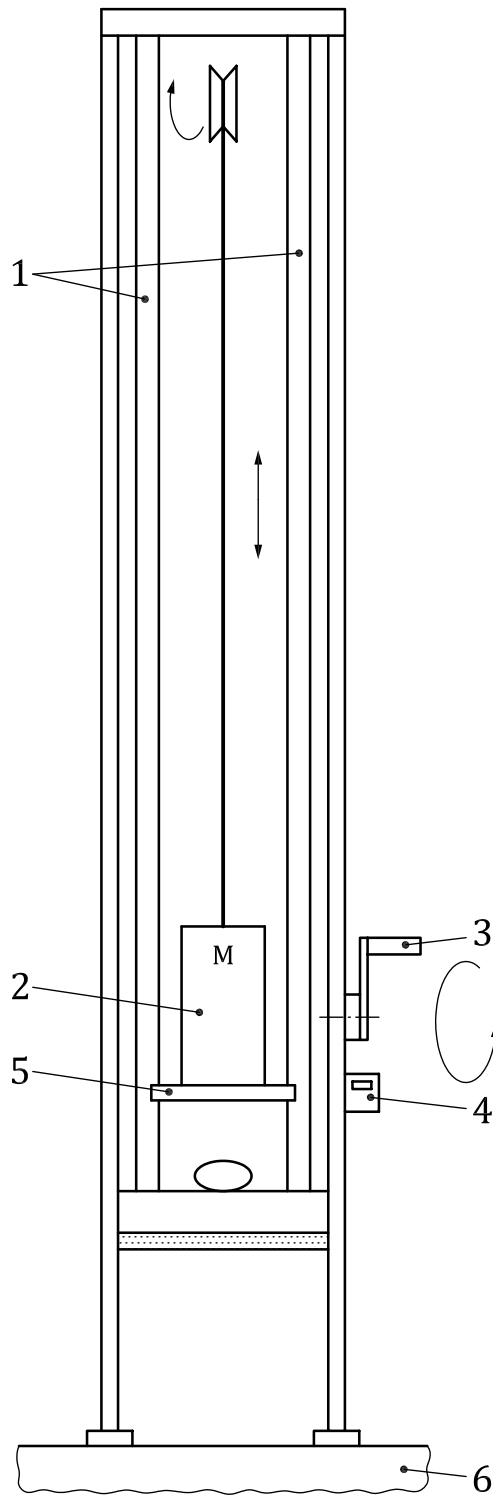

Key

- | | | | |
|---|---------------|---|--------------|
| 1 | guide runners | 4 | height gauge |
| 2 | mobile gantry | 5 | impact plate |
| 3 | manual winch | 6 | frame base |

Figure C.2 — Impact resistance test apparatus

C.2.4 Requirement

Following this test, no rupture of the implant shell shall be present on the mammary implant when observed visually at a $\times 10$ magnification.

C.2.5 Test report

At least, the following information shall be reported:

- a) description of specimen, including manufacturer, model, serial number or lot code and the prostheses projection;
- b) description of the test equipment used;
- c) test results; in case of failure, a description of failures visually observed;
- d) testing date;
- e) identity of the responsible tester.

Annex D (normative)

Test method for valve competence and injection site competence

D.1 Valve competence

D.1.1 Principle

This test method determines valve competence. This test shall only be carried out for inflatable implants.

D.1.2 Materials

Inflatable implant.

D.1.3 Procedure

The valve shall be tested on an assembled implant as follows.

Prior to testing, manipulate valve to simulate its use for filling an implant, as described in the instructions for use

Apply an increasing retrograde pressure (pressure to the inner or lumen side of the valve) equivalent to $(3,0 \pm 0,3)$ kPa [approximately (300 ± 30) mm of water] using air, water or a test medium with demonstrated equivalence. Maintain this pressure for $(5,0 \pm 0,1)$ min. [Figure D.1](#) shows a schematic assembly test system.

Examine the valve for leakage. When the test medium is air, immerse the valve in water to check for leaks (bubbles). If liquid test media are used, check for droplets which might emerge at the outer surface of the valve.

Reduce the pressure to the equivalent of $(0,3 \pm 0,1)$ kPa (approximately 30 mm water). Hold at this pressure for $(5,0 \pm 0,1)$ min and check for leaks.

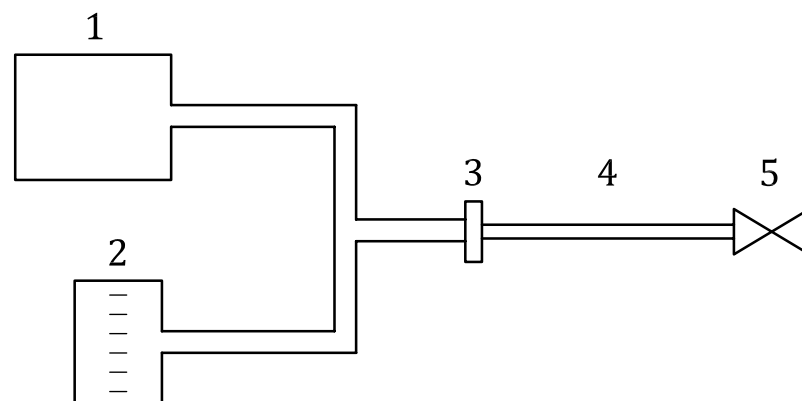

Key

- | | | | |
|---|-----------------|---|---------------|
| 1 | pressure system | 4 | implant lumen |
| 2 | manometer | 5 | implant valve |
| 3 | coupling device | | |

Figure D.1 — Schematic testing system

Licensed to Establishment Labs (purchasing@establishmentlabs.com)
ISO Store Order: OP-283853 / Downloaded: 2018-04-19
Single user licence only, copying and networking prohibited.

Examine the valve for leakage. When the test medium is air, immerse the valve in water to check for leaks (bubbles). If liquid test media are used, check for droplets which might emerge at the outer surface of the valve.

D.1.4 Requirement

No leakage shall occur during the test period.

D.2 Injection site competence

D.2.1 Principle

This test method determines injection site competence.

D.2.2 Materials

Needles recommended by the manufacturer for normal use.

Water, or a test medium with demonstrated equivalence.

D.2.3 Procedure

The injection site of the assembled device shall be tested with needles recommended by the manufacturer for normal use.

Using water or a test medium with demonstrated equivalence, apply an intraluminal pressure of $(3,0 \pm 0,3)$ kPa [approximately (300 ± 30) mm of water].

Puncture the injection site for a total of five times at 1 min intervals within a 1 mm^2 area near the centre of the site.

Examine the injection site for leakage. When the test medium is air, immerse the site in water to check for leaks (bubbles). If liquid test media are used, check for droplets which might emerge at the outer surface of the site.

D.2.4 Requirements

The implant does not meet injection site leak requirements if droplets of fluid or bubbles appear, and continue to appear after 30 s, on the punctured surface.

D.3 Test report

At least, the following information shall be registered:

- a) description of implant specimen, including manufacturer and serial number or lot code;
- b) testing date;
- c) identity of the responsible tester;
- d) indication of the valve competence or injection site competence, according [D.1.4](#) or [D.2.4](#).

Annex E (normative)

Test for silicone gel cohesion (silicone filling materials only)

E.1 Principle

This test method determines the cohesion of the silicone gel.

E.2 Materials

Silicone gel collected from an implant.

E.3 Apparatus

Test apparatus as shown in [Figure E.1](#), internal volume (100 ± 5) ml.

The value of internal surface roughness, Ra , shall be the mean height of the profile below and above the line, as defined in ISO 4287.

E.4 Procedure

The test shall be performed at a temperature of (23 ± 2) °C, as follows.

a) Fill the apparatus with the gel.

A representative test sample of the gel should be collected from a single implant of sufficient size to allow gel to be removed as one cohesive mass.

Care should be exercised when removing the gel and transferring it to the test fixture. Severe mixing, handling, air entrapment, etc. will produce erroneous results.

b) At the beginning of the test, the gel shall be flushed with the lower surface of the apparatus and shall be flushed with, or above, the top surface.

c) Allow the gel to flow unrestricted through the lower opening for $(30,0 \pm 0,1)$ min.

d) Note if any gel separates from the test volume.

e) Measure the projecting length of the gel.

Dimensions in centimetres,
value of surface roughness in micrometres

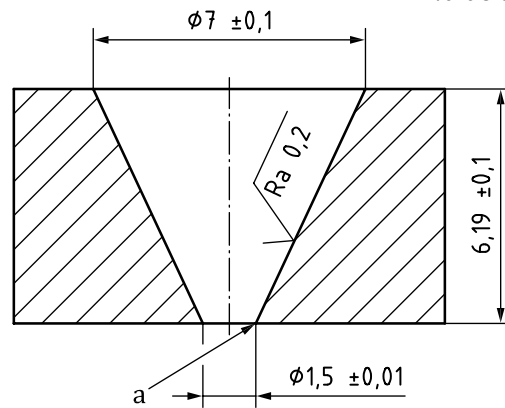

a Sharp angle.

Figure E.1 — Test for gel cohesion

E.5 Requirements

The specimen shall meet the requirements of the test if there is no separation and the projecting length of the gel is less than or equal to 30 mm.

E.6 Test report

At least, the following information shall be reported:

- description of specimen, including manufacturer, model, serial number or lot code;
- specimen performance result, and the measure of the projection length of the gel;
- testing date;
- identity of the responsible tester.

Annex F (normative)

Test for silicone gel penetration (silicone filling materials only)

F.1 General

The penetration test is a quantitative determination of the firmness of gel used within the mammary implant. The test is based on examining the gel as an in-process step to verify adequacy of the mixing protocol and to verify mix ratios prior to manufacture of the device. Cure takes place within the test cup at cure conditions which simulate actual production conditions. A penetrometer method and an alternative (texture analyser) method are outlined below.

F.2 Apparatus

F.2.1 Equipment for penetrometer procedure

- a) **Universal penetrometer or equivalent (capable of measuring to 0,1 mm)**, as shown in [Figure F.1](#);
- b) **Weight of penetrometer rod and foot assembly should be chosen for a particular gel and should be within $\pm 0,5$ g for all tested specimens;**
- c) **Penetrometer rod**, size chosen to allow for unrestricted movement of foot within the test cup;
- d) **Penetrometer foot**, diameter chosen for suitability with other apparatus to provide consistent results. Penetrometer foot size, test cup size and fill level shall be chosen to ensure that there is no impact of the jar on test results. The radius of the foot shall have 1,3 cm clearance from edges of test cup, the cup shall not overflow upon submergence of foot and the bottom of the foot should never be less than 2,5 cm from the test cup base;
- e) **Penetration test cup**, size chosen for suitability with other apparatus to provide consistent results;
- f) **Foot and test cup selection shall be chosen to ensure there is no interaction;**
- g) **Balance.**
- h) **Timer.**
- i) **Isopropyl alcohol.**
- j) **Foam wipe.**

F.2.2 Equipment for texture analyser

- a) **Texture analyser**, as shown in [Figure F.2](#);
- b) **Probe.**
- c) **Penetration test cup**, size chosen for suitability with other apparatus to provide consistent result;
- d) **Balance.**
- e) **Timer.**

- f) **Isopropyl alcohol.**
- g) **Foam wipe.**

F.3 Procedure

F.3.1 Test specimen preparation

- F.3.1.1** At least three test specimens shall be taken from each and every lot.
- F.3.1.2** Mix gel at the prescribed ratio. De-air completely.
- F.3.1.3** Fill test cup with gel to specification.
- F.3.1.4** Label properly.
- F.3.1.5** Cure gel test specimen. Allow sample to cool to room temperature before testing.

F.3.2 Penetrometer procedure

- F.3.2.1** Clean specified penetrometer foot and shaft with isopropyl alcohol and foam wipe. Allow to dry at ambient conditions for 5 min minimum.
- F.3.2.2** Place cured gel test specimen in the centre of the penetrometer platform and under the penetrometer foot.
- F.3.2.3** Zero the penetrometer depth gauge per equipment instructions.
- F.3.2.4** Lower rod and foot assembly over the test specimen so that the foot just touches the surface without making any indentation, taking care to handle gently.
- F.3.2.5** Simultaneously depress the timer start button, depress trigger of the penetrometer, hold it down for the specified number of seconds, and then rapidly release it. If not otherwise specified, hold time is 5 s. During this time, foot and rod have penetrated the test specimen

NOTE Certain penetrometers are equipped with automated timing and penetrometer release mechanisms, thus negating the need for a separate timer or to physically depress the penetrometer release trigger.

- F.3.2.6** Gently depress the depth gauge as far as it will travel. Penetration of the test specimen is read directly from the dial as indicated by the pointer. Record penetration result to the nearest 0,1 mm.
- F.3.2.7** Results are to be recorded and be within manufacturers expected results. Report individual replicate results and verify if they meet the specifications and vary less than 10 % from median. Unless

otherwise specified, disregard results and repeat previous steps if any replicate differs more than 10 % from the median.

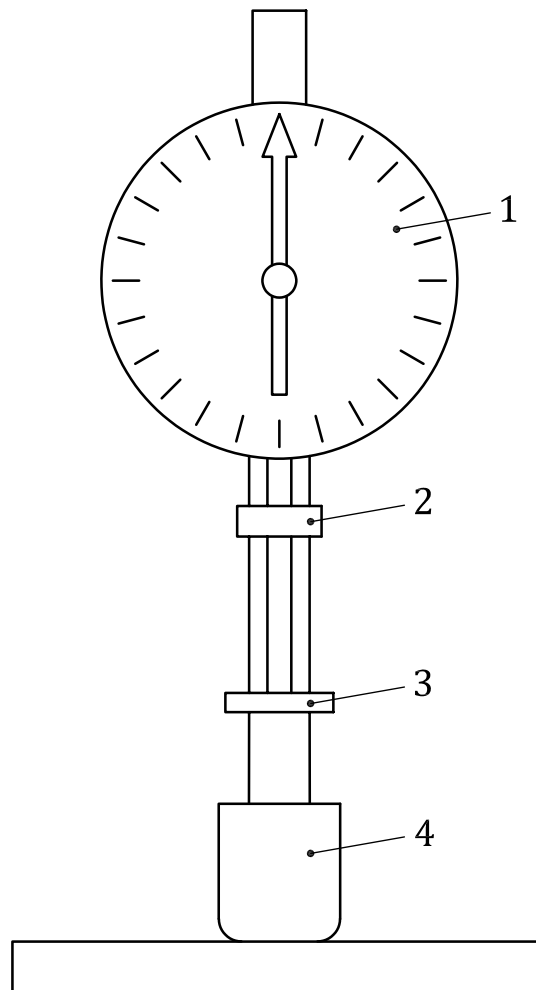

Key

- | | | | |
|---|-----------------|---|-------------------|
| 1 | graduated scale | 3 | penetrometer foot |
| 2 | release button | 4 | test cup |

Figure F.1 — Penetrometer diagram

F.3.3 Procedure for texture analyser

F.3.3.1 Turn on texture analyser per equipment instructions.

F.3.3.2 Calibrate texture analyser per equipment instructions. The force employed for testing shall be within the calibrated range of the load cell.

F.3.3.3 Load specified test program from texture analyser software program.

F.3.3.4 Clean specified texture analyser probe with isopropyl alcohol and foam wipe. Allow to dry at ambient conditions for 5 min minimum.

F.3.3.5 Place cured gel test specimen in centre of texture analyser platform and under texture analyser probe.

F.3.3.6 Verify texture analyser probe is centred above test specimen.

F.3.3.7 Lower texture analyser probe until it is approximately 1 cm above cured gel surface.

F.3.3.8 Begin test per equipment instructions.

F.3.3.9 Repeat F.3.3.1 to F.3.3.8 using the remaining two replicates.

F.3.3.10 Report individual replicate results and verify if they meet the specifications and vary less than 10 % from median. Unless otherwise specified, disregard results and repeat previous steps if any replicate differs more than 10 % from the median.

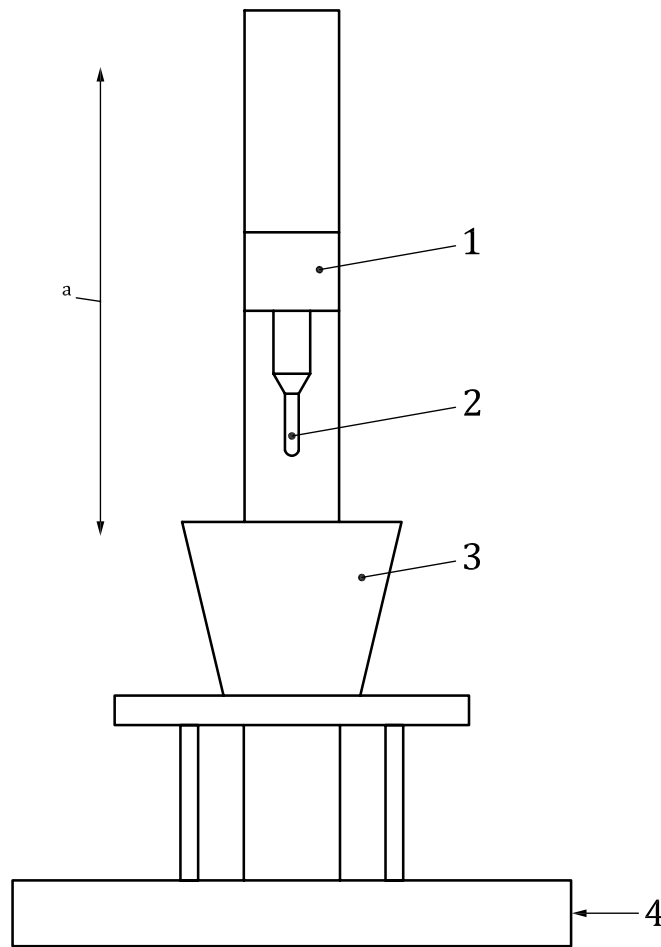

Key

- | | | | |
|---|------------------------|---|------------|
| 1 | penetrometer head | 3 | sample cup |
| 2 | penetrometer probe | 4 | base |
| a | Direction of movement. | | |

Figure F.2 — Texture analyser diagram

F.4 Remarks

- a) Gel penetrometer results are valid only for comparisons with a manufacturer’s product line. They are not valid for comparisons between manufacturers as slightly different test method or test apparatus can provide different results.

- b) Differing weight may be chosen depending on the suitability of any weight to accuracy of measurement of the gel.
- c) Alternative test methods may be used where test method is shown to be applicable.

F.5 Test report

At least, the following information shall be reported:

- a) description of specimen, including lot code;
- b) specimen performance result;
- c) testing date;
- d) identity of the responsible tester;
- e) test equipment;
- f) analyser parameters.

Annex G (informative)

Assessment of silicone diffusion from mammary implants using an in vitro method

G.1 Principle

The test consists of submerging of the implants while stirring in a simulated body fluid (SBF) at (37 ± 2) °C. This *in vitro* procedure is supposed to simulate the pH and ion concentrations found in human plasma (the composition of the SBF is given in [G.2.3](#)) and to evaluate the amount of silicone released at the time point when the amount of silicone released by the gel stabilizes.

The analyses are performed by inductively coupled plasma optical emission spectrometry (ICP-OES). Determination of the silicone amount released by the implant is based upon the measurement of silicone in the aliquots/solution samples of SBF taken regularly from the solution.

At the end of the study, the results are treated in order to express the total amount of silicone released by the implant as a function of the following elements:

- a) the exact amount of SBF surrounding the implant;
- b) the volume taken from the solution for the measurement of silicone;
- c) the theoretical ratio silicon/silicone.

G.2 Material and apparatus

G.2.1 General

G.2.1.1 Orbital shaker, the rotation shall be efficient enough to allow the implants to be stirred properly with the least contact possible with the wall of the container.

G.2.1.2 ICP optical emission spectrometer.

G.2.1.3 Standard silicon solution.

G.2.1.4 SBF.

G.2.1.5 Plastic leak-proof containers, the containers used to perform the analysis shall not interact with SBF and shall have a shape allowing a proper submergence of the implant with the least contact possible with the wall of the container (volume between $7 \times$ to $9 \times$ volume of breast implant).

G.2.2 Sampling preparation

To ensure that all the implants occupy the same volume and are properly submerged in the SBF solution, the inflatable implants shall be saline filled to their nominal volumes.

G.2.3 Simulated body fluid (SBF)

Composition of simulated body fluid shall be as indicated in [Table G.1](#).

Table G.1 — Composition of simulated body fluid

Ion	Content mmol/l
Na ⁺	142,0
K ⁺	5,0
Mg ²⁺	1,5
Ca ²⁺	2,5
Cl ⁻	147,8
HCO ₃ ⁻	4,2
HPO ₄ ²⁻	1,0
SO ₄ ²⁻	0,5

G.2.4 SBF preparation

[Table G.2](#) gives the quantities of added salt to meet for meeting the requirements of ionic molar concentrations specified in [G.2.3](#), for preparing 5 l of SBF.

In a 5 l volumetric flask, put 4 l of ultrapure water and add the salts by respecting the order stated in the table below. Dissolve each salt before adding to the next.

Table G.2 — Composition of simulated body fluid for a 5 l volumetric flask

Salt	Mass mg
Na ₂ SO ₄	355
NaHCO ₃	1 765
KCl	1 865
MgCl ₂ ·6H ₂ O	1 525
CaCl ₂ ·2H ₂ O	1 820
NaCl	39 400

At the end, add 1 790 mg of Na₂HPO₄·12H₂O previously dissolved in 200 ml of ultrapure water. This forms a white turbidity in the solution.

To find a clear solution, add a few ml of HCl 1N solution with a pipette. Shake vigorously between each addition of acid and wait for a few minutes in order to the redissolution takes place.

When the solution is clear, complete the volume of the flask at 5 l with ultrapure water and homogenize.

Check the SBF pH is close to 7,0. If the pH is higher, it is possible to add some HCl to lower it. If the pH is lower, prepare a new solution of SBF.

The freshly prepared SBF shall not be stored in the glass jar, but be transferred into a clean plastic container.

G.2.5 Material preparation

Plastic containers used to perform the study shall be cleaned prior to use to ensure the removal of any silicone mould release agents used in their manufacture, or other contaminants. They shall be filled with a solution of detergent, closed tightly and stirred on the orbital shaker, then rinsed out thoroughly with water and dried with a tissue.

G.3 Procedure

G.3.1 General

Take eight solution samples at $T = 0$ d, 10 d, 20 d, 30 d, 40 d, 50 d, 60 d and 70 d (± 2 d).

If one of them seems out of range, another one shall be performed the day after (so T can be +3 d).

G.3.2 Condition of release determination and Si measurements

The test shall be performed on worst case size implants in triplicate.

If the worst case size implant volume is greater than 500 cm^3 , technical limitations of the test methodology may require to perform the test on an implant of the nearest appropriate volume less than 500 cm^3 .

The implant (silicone gel-filled or saline-filled), having a volume V_i (ml), shall be placed in a plastic container. A volume of $6V_i \pm 0,03V_i$ of SBF shall be added.

The container shall be closed tightly, the solution heated at $(37 \pm 2) \text{ }^\circ\text{C}$, and stirred for 1 h on an orbital shaker. $(10,0 \pm 0,1)$ ml of SBF shall be taken for analysis and the same volume of fresh SBF shall be added. This initial sampling constitutes the $T = 0$ data for each implant tested.

The container shall then be placed in an oven at a constant temperature of $(37 \pm 2) \text{ }^\circ\text{C}$ and stirred for (10 ± 1) min every day on the orbital shaker.

$(10,0 \pm 0,1)$ ml of SBF shall be removed every 10 days for analysis by ICP-OES, and the same volume of fresh SBF shall be added.

It is also possible to weigh the container with the SBF and the implant each time $(10,0 \pm 0,1)$ ml has been taken for analysis, and to add SBF until the initial mass is obtained. This operation compensates for the amount of SBF lost when handling the device.

$(10,0 \pm 0,1)$ ml of SBF shall be removed every 10 days for analysis by ICP-OES, and the same volume of fresh SBF shall be added. Six samplings are thus performed at 10 d, 20 d, 30 d, 40 d, 50 d, 60 d (± 2 d). If one of them seems out of range, another one shall be performed the day after (i.e. T can be +3 d).

The silicon shall be analysed within 1 h after being taken from the reaction medium.

Before every set of measurements, the spectrograph shall be calibrated with silicon standards prepared in SBF from a $(1\ 000 \pm 10) \text{ } \mu\text{g/ml}$ standard solution in water. The concentration of these standards depends on the results of the previous analysis.

The silicon standard chosen shall be certified by an accredited laboratory.

G.3.3 Expression of the results

Each solution sample shall be analysed several times to obtain a mean concentration of silicon and a standard deviation for each time period.

For each type of implant, the results shall be expressed in mass of silicon and mass of silicone released by the implant as a function of the time.

If

V is the volume in ml of SBF added at $T = 0$,

x_0 is the concentration of silicon measured at $T = 0$ ($\mu\text{g/ml}$),

V_{P1} is the volume in ml removed at $T_i = 10$ d,

x_1 is the concentration of silicon measured at $T_i = 10$ d ($\mu\text{g/ml}$),

V_{P2} is the volume in ml removed at $T = 20$ d,

x_2 is the concentration of silicon measured at $T = 20$ d ($\mu\text{g/ml}$),

the accumulated amount of silicon X_i (mg) extracted from the implant sample at each sampling time shall be determined as follows:

at day 0, $X_0 = (x_0 \times V)/1\ 000$;

at day 10, $X_1 = (x_1 \times V)/1\ 000 + (x_0 \times V_{P1})/1\ 000$;

at day 20, $X_2 = (x_2 \times V)/1\ 000 + (x_1 \times V_{P2})/1\ 000$;

at day i , $X_i = (x_i \times V)/1\ 000 + (x_{i-1} \times V_{Pi})/1\ 000$.

The elemental silicon given by ICP-OES shall be converted into the total amount of silicone. This conversion is done to determine the total amount of polydimethylsiloxane released from individual implants. The concentration, expressed mole to mole, is calculated from the silicon concentration (milligrams per kilogram) to the mass (mg) of silicone.

The value of the silicone/silicon ratio is calculated from the theoretical ratio given by the 12th edition of the Merck Index (part dimethicone) with the pattern $[-(\text{CH}_3)_2\text{Si-O-}]$: silicon $\times 2,64 =$ silicone.

Annex H (informative)

Test for surface characteristics

H.1 Principle

This test determines the average surface characteristics of mammary implants.

H.2 Materials

Mammary implant elastomer shells of finished devices.

H.3 Apparatus

H.3.1 General

The characteristics of the shell surface should be recorded by an appropriate surface metrology system or by electron microscopy.

The use of ISO 25178-2 or ISO 4287, and any setting and/or adjustment method should be documented.

H.3.2 Surface metrology

The surface should be characterized with either optical, non-contact or contact profilometry, that is, with at least one of the following options:

- a) White Light Interferometry: Should be performed with a White-Light Interferometric Microscope suitable for the surface dimensions.
- b) Laser Confocal Microscopy: Should be performed by a non-contact Laser Confocal Microscope with a height range suitable for biological purposes.
- c) High Range Atomic Force Microscopy: The atomic microscopy should be performed with an atomic force microscope and the adjustment method used should be documented. Atomic Force Microscopy with a large scanning range should preferentially be used in the tapping mode and the adjustment mode should be documented; the probe used for microscopy should be suitable for the material based on the sensitivity and accuracy of the tip on the test specimen.

H.3.3 Surface topography imaging

Surface topography imaging should be performed through electron microscopy with a scanning electron microscope (SEM). The test specimen preparation should be made suitable for the sample surface and recorded.

H.4 Test specimen preparation

The surface characterization should be measured over areas of $(4,0 \pm 0,1) \text{ mm}^2$.

Take five measurements from the base, radius, and anterior surfaces of each of three representative textured shells.

The test specimen should be labelled properly, including the area where they were taken from, to avoid any confusion or misplacement.

The test specimen shall be prepared and cleaned with a dried non-damaging purifying solution such as isopropanol or ethanol that will prevent the surface from swelling in order to eliminate all possible contaminants. Handling and storing of samples shall be made appropriately in order to avoid dust contamination.

Further preparation of the test specimen shall be suitable for the test specimen required by the corresponding apparatus and the procedure should be recorded.

H.5 Data to be recorded

The method used combines the use of a scanning electron microscope and 2D and 3D surface reconstruction software, and statistical analysis. ISO 25178-2 and ISO 4287 can be used for the calculation of the surface parameters.

The following surface features should be measured and recorded for each sample:

- a) Pore size or pore diameter (μm),
- b) Number and height (μm) of peaks and resulting kurtosis,
- c) Number and depth (μm) of valleys and resulting skewness,
- d) Average distance between morphological features (μm), i.e. morphological density,
- e) Mean peak height (μm),
- f) Arithmetic roughness (R_a or S_a) and Root mean square roughness (R_{ms}),
- g) Maximum peak height (R_z or S_z).

NOTE Certain of the above features are not applicable for all texture types.

The position of the measurements within each sample should be recorded for the profilometry and scanning electron microscopy, in order to compare the data obtained with the topography.

The average measurements and standard deviation of the characteristics should be recorded.

ISO 25178-2 and/or ISO 4287, if used, and any setting and/or adjustment method should be documented.

The choice of the analysis approach of the raw data including software settings for evaluating shall be documented. Raw data shall be kept according to the applicable regulations.

H.6 Expression of results

The obtained data is meant to generate information to improve knowledge on the correlation of texture characteristics, performance and safety.

Based on the average roughness measurement on the finished device, the surface can be described by the following:

- smooth: less than $10 \mu\text{m}$;
- microtextured: from $10 \mu\text{m}$ to $50 \mu\text{m}$; and
- macrotextured: over $50 \mu\text{m}$.

NOTE The data resulting from the test at this point in time cannot be related to the performance or safety of the device, but enough data points should be collected to have the ability to study such relation.

H.7 Test report

At least, the following information should be reported:

- a) a description of specimen, including manufacturer, model, serial number or lot code;
- b) the specimen performance result;
- c) the testing date;
- d) the equipment used;
- e) the identity of the responsible tester.

Annex I (normative)

Information for the user

As a minimum, the following information shall be provided:

- a) indications for surgery;
- b) description of the implant;
- c) instructions for use;
- d) contraindications;
- e) potential complications and their possible resolution;
- f) precautions for the surgery;
- g) instructions and precautions for removal;
- h) recommendations for medical follow-up;
- i) expected lifetime, expressed in accordance with [11.6](#);
- j) a statement requiring the surgeon to ensure that the patient will receive the minimum information described in [11.7](#), provided by the manufacturer;
- k) at least all the information available to fulfil [11.7](#).

When orientation means are required, the location and recommended techniques for use shall be clearly described in the labelling.

Annex J (normative)

Information for the patient

This information is intended to be given to the patient by the user well before the surgery.

The information shall be provided in a format that is easily accessible to patients.

The information to the patient shall include:

- a) name or trade name, and address of the manufacturer;
- b) description of the implant, including type, materials and principles (e.g. prefilled or inflatable implant), chemical components in general terms (e.g. silicone), characteristics (e.g. textured or smooth);
- c) expected lifetime, expressed in accordance with [11.6](#);
- d) the following warning: “Mammary implants have a limited lifetime”, and the following statement: “This implant may have to be removed or replaced, which is classified as revision surgery”;
- e) anticipated benefits;
- f) anticipated risks: the information includes all the potential local complications, such as capsular contracture, rupture (mentioning the possibility of “silent” rupture), leakage, deflation, and wrinkling; the potential general effects on health shall also be indicated;
- g) adverse effects;

NOTE The manufacturer should justify the completeness of the list of anticipated risks and adverse events.

- h) possible effects of the implant on breast feeding;
- i) the need to consult a surgeon for medical follow-up;
- j) the need to consult a physician or a pharmacist before the use of topical medicines (e.g. steroids) in the breast area;
- k) the need to continue to consult a physician to carry out normal checks in order to detect breast cancer;
- l) effects of the implant on diagnostic techniques such as mammography;
- m) the need to inform the radiologist if a mammography is carried out in order to adapt the mammographic compression;
- n) possible effects of the implant on autopalpation;
- o) an indication that the patient should consult a physician if the patient suspects any complications, in particular in the case of trauma or compression caused, for example, by some sport activities or by using seat belts;
- p) the recommendation to patients that, to facilitate medical care, they carry the patient card at all times in case of an emergency.

Bibliography

- [1] ISO 11607-2, *Packaging for terminally sterilized medical devices — Part 2: Validation requirements for forming, sealing and assembly processes*
- [2] ISO/TR 14283, *Implants for surgery — Fundamental principles*
- [3] ISO/TR 14969:2004, *Medical devices — Quality management systems — Guidance on the application of ISO 13485: 2003*
- [4] ISO 14971, *Medical devices — Application of risk management to medical devices*
- [5] ISO 16054, *Implants for surgery — Minimum data sets for surgical implants*
- [6] ISO 25178-2, *Geometrical product specifications (GPS) — Surface texture: Areal — Part 2: Terms, definitions and surface texture parameters*
- [7] CR 14060, *Medical device traceability [CEN Report]*
- [8] MEDDEV 2.7.1, *Guidelines on Medical Devices — Evaluation of Clinical Data: A guide for manufacturers and notified bodies*
- [9] ICH Guideline for Elemental Impurities Q3D (2014) http://www.ich.org/fileadmin/Public_Web_Site/ICH_Products/Guidelines/Quality/Q3D/Q3D_Step_4.pdf
- [10] ASTM F703–18, *Standard specification for implantable breast prostheses*

